

# BW-9700 热保护器

## BW-9700 Series Thermal Protector

### 结构特点 Features or structure

BW-9700 系列热保护器是由碟形高灵敏双金属元件、动触头、静触片、固定底座、外壳、耐高温导线等组成。工作时双金属元件处于自由状态，动触头与静触片闭合，电路导通。当使用电器因故障发热而使温度上升至热保护器的动作温度时，双金属元件受热产生内应力而迅速动作，推开动触头离开静触片而断开电路，从而切断故障电器电源起到保护电器作用。当被保护电器温度下降到热保护器的额定复位温度值时，双金属元件恢复到初始状态触点闭合，电器恢复正常工作。该产品具有电阻小、感温快、动作迅速、安全可靠、体积小等优点。

BW-9700 series thermal protector consists of dish shape high sensitive bimetallic element, movable contact-head, static contact-piece, soleplate, outer case, thermal resistant lead and so on. When operation, the bimetallic element is in free state and movable contact-head and static contact-piece are closed and the circuit is on. When the electric appliance is in operation and produces heat caused by some troubles and temperature is raised to the rated action temperature of the product, the bimetallic element produces inner stress and acts quickly and pushes the movable contact-head and make the contact point off and the power supply is turned off the electric appliance stop. In this way the thermal protection is made. When the temperature of electric appliance to be protected is dropped to the rated reset temperature. The bimetallic element restores to its primary state and contact point is closed. The electric appliance restores its work. The product has many advantages such as small resistor, quick in temperature feeling, fast in action. Safe and reliable. compact and so on.

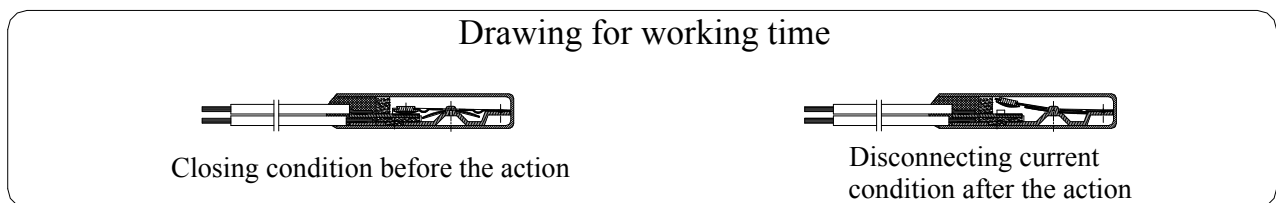
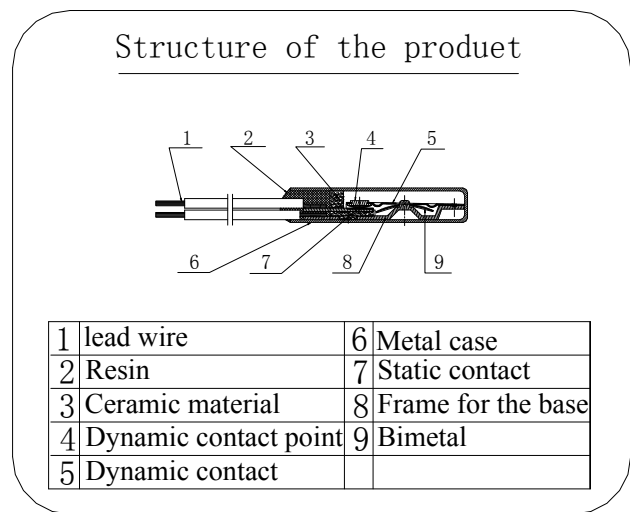
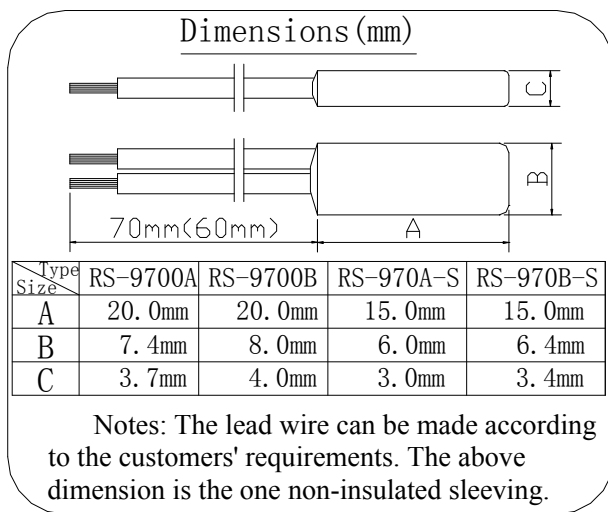

型号说明 The model number explain

BW-9700ABJ: 金属外壳型产品 The metals outer shell type product.

BW-9700ABS: 塑料外壳型产品 The plastics outer shell type product.

金属外壳型产品其外壳为带电体, 应加装绝缘外套 The metals outer shell type the product outer shell take an electricity, should add to insulate a coat.

## BW-9700 热保护器

### BW-9700 Series Thermal Protector

#### 应用范围 Product application

适用于各种家用电器和电子产品。如马达、日光灯镇流器、电池充电器、变压器、园筒形线圈、电蒸气浴机、电热水器、办公自动化设备等的过热保护。

Be applicable to all kinds of home appliances and electronics products. Such as Electric Motors, Fluorescent Ballasts, Battery Chargers, Transformers, Solenoids, Heating pads, OA-Machines ETC.

#### 技术参数 Technical parameters:

动作温度 Action temperature	复位温度 Reset temperature	动作温度 Action temperature	复位温度 Reset temperature
45±5℃	40±6℃	105±5℃	80±15℃
50±5℃	43±6℃	110±5℃	80±15℃
55±5℃	45±6℃	115±5℃	85±15℃
60±5℃	50±10℃	120±5℃	90±15℃
65±5℃	50±10℃	125±5℃	95±15℃
70±5℃	50±10℃	130±5℃	100±15℃
75±5℃	55±10℃	135±5℃	105±15℃
80±5℃	55±10℃	140±5℃	110±15℃
85±5℃	55±10℃	145±5℃	115±15℃
90±5℃	60±10℃	150±5℃	120±15℃
95±5℃	65±10℃	155±5℃	125±15℃
100±5℃	75±10℃	160±5℃	130±15℃

特殊规格可根据客户要求定做 The specification can also be manufactured as request.

额定电压 Rated Voltage :AC250V/AC125V;

额定电流 Rated Current:1~10

常态电气强度 Electric intensity: > 800V

常态接触电阻 Contact resistance: < 30mΩ

绝缘电阻 Insulation resistance: > 100MΩ

响应速度 Response speed: ≤1℃/min

寿命次数 Number of automatic cycles: > 6000(阻抗负荷 Resistive Load)

**温度检测方法:** 将试样两引线分别接在测试设备的夹具上, 通上 10mA 左右的电流(不超过 100mA), 用一发光二极管指示电流的通断, 然后将试样放入专用测温设备内, (测试设备内温度应均匀, 加热升温速度可控制) 温度计探头应贴近试样, 控制检测设备温度以 0.5~1℃/min 的速率升温, 当发光二极管熄灭时, 记下温度计读数即为试样的动作温度。

**TEST METHOD:** Sample is connected to the fixture of the equipment, and placed into the test equipment (Hot current of air in the space of test should be equipped with a stirrer and temperature is controllable). A detect current about 10mA (no more than 100mA) is passed through the sample and a thermometer is placed junction to the sample to monitor the opening temperature. The temperature of the test equipment is raised at the rate of 0.5~1℃ per minute until the sample functioned.