

TD-POWER

marine

2003/44/EC APPROVED

TDME series marine diesel engine

Operation manual

Jiangyan Xinyang Machine-building Co., Ltd
East Xingjiang Road Private Economic Center, jiangyan City, Jiangsu, China

Contents

1. Foreword
2. General information
3. Engine component guide
4. Running Instructions
 - 4.1 Starting the engine
 - 4.2 Running instructions
 - 4.3 Shutdown procedure
5. Checks and service
 - 5.1 Check daily before starting
 - 5.2 Check every 14 days
 - 5.3 Service every 50 hours of operation
 - 5.4 Service every 100 hours of operation
6. Laying-up and launching
7. Fault Tracing Scheme
8. Technical Data
9. Electric Wiring Diagrams

IMPORTANT INFORMATION

Stop the engine before opening the hatch to the engine compartment. An engine which is in operation has rotating and moving parts which are dangerous to touch.

Bear in mind the risk of a fire. All engine fuel is inflammable. The cooling system is filled with liquid and it should be drained when there is risk of frost. Note that in certain cases a suction action may occur when the seawater system is being drained. Close all drainage points when the boat is not under constant supervision. Incorrectly performed drainage can cause the boat to become filled with water and sink.

1. Foreword

1.1 Introduction

This introduction book provides helpful information for running and maintaining your marine diesel engine.

The content apply to particular engines specifications. Each engine is supplied from TD-POWER in accordance with the published specifications.

Examine your engine and other components to be able to find them in this book. Read this book carefully before operating the engine. Don't wait until a problem occurs.

1.2 Safety Notice

The following warning notes will alert you to possible bodily injury dangers and to important information on safe operation of equipment. Observe them carefully.

“Warning” notes alone do not eliminate the dangers that they signal. Personal close attention of equipment are major accident prevention measures.

WARNING: You are warned that personal injuries, damage to property or malfunction of the engine can result from your not following these instructions.

2. General information

Important information concerning the function to your engine

2.1 Fuel

Users can select the proper grade of fuel according to the local ambient temperature as follows:

ASTM D975No.1-D No.2-D.....for USA

EN590:96.....for EU

ISO8217DMX.....international

BS2869-A1 A2.....for UK

JIS K2204.....for JAPAN

Before being filled into the engine fuel tank, the diesel fuel must be settled for a long period (normally at least 48h). Then draw out the upper part. The fuel should be filtered by silk cloth while filling into the fuel tank. Also let the fuel settle. It will extend service life of injectors and injection pumps.

2.2 Lubricating Oil

You should use 15W/40 lube oil for every ambient temperature. Filter the oil before filling into the engine

2.3 Cooling Water

It's recommended to use soft water for engine cooling system, such as rain water, or city tap water, or clean river water, also it is necessary to add anti-freeze to the soft water before filling into the engine when the engine operates in the cold weather. Cooling water containing too much minerals will form water scale in an engine cooling system, affecting the engine cooling efficiency and giving rise to engine troubles.

If it's difficult to start the engine under lower ambient temperature, heat the water to about 80°C before filling it into the cooling system.

2.4 Running In

A new engine diesel engine requires careful running in during the first 20 working hours. Run the engine as for normal operations but do not load the engine fully during this period. Unnecessary idling with an unloaded engine should always be avoided. A greater consumption of lubricating oil during the running-in period is

usual. Check the oil level more often during the running-in period.

2.5 Preparation Before Starting

Before starting engine make sure that:

There is no **FUEL LEAKAGE**

There is no **WATER LEAKAGE**

There is no **OIL LEAKAGE**

There is no **SMELL OF LP-GAS** in the deep cavities of the boat or elsewhere

The **OIL LEVELS** are correct

The **COOLING WATER LEVEL** in the expansion tank for the fresh water system is correct.

The proper **NAUTICAL CHARTS** are on board for the planed voyage

There is enough **FUEL** on board for the planed voyage

Make sure when filling your fuel tank that there is no open flame on board.

Ventilate the boat and run the engine room fan (if fitted) for 4 minutes before starting the engine. Do not overfill fuel tank.

3. Engine Component Guide

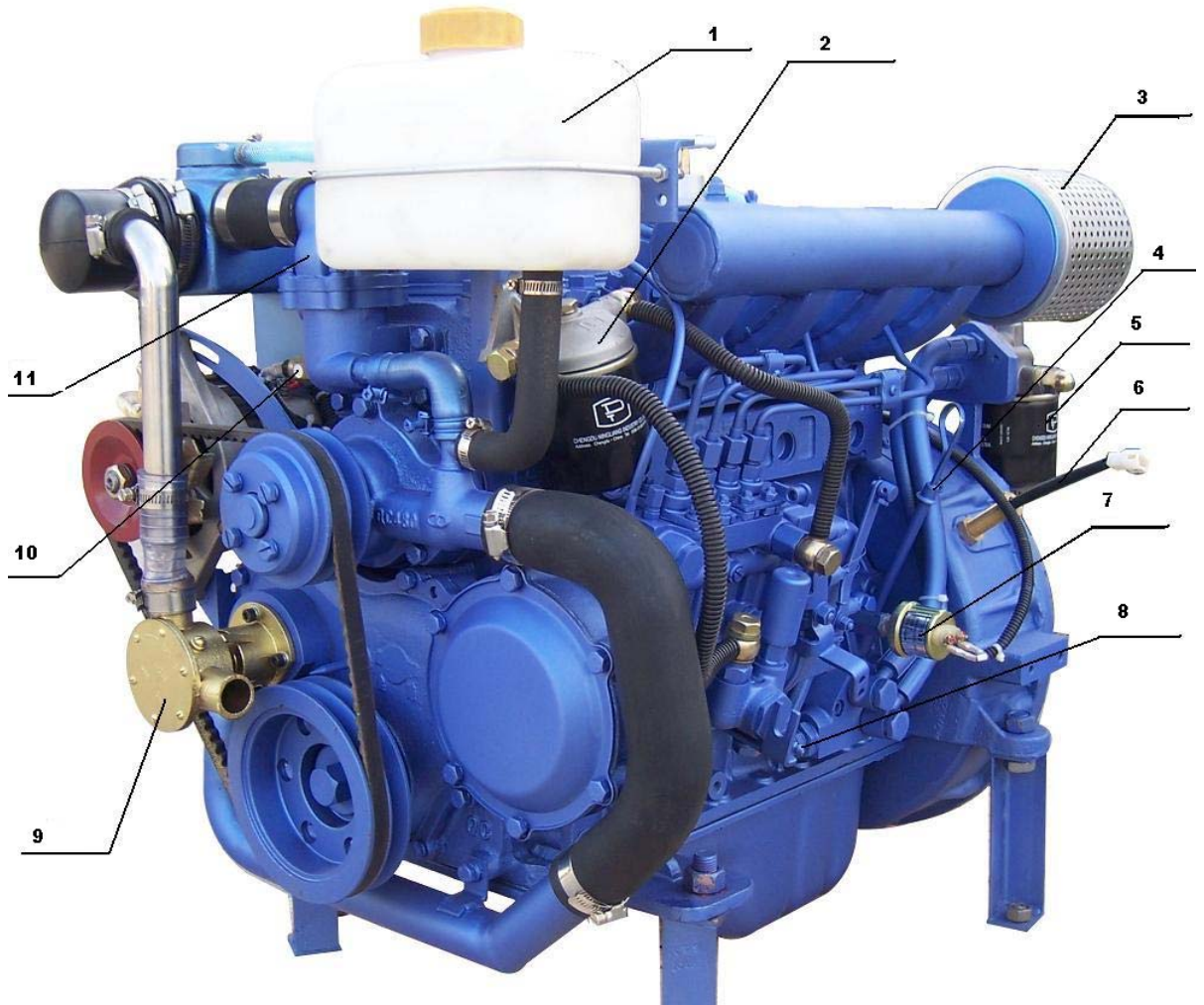

1. EXPANSION TANK
2. FUEL FILTER
3. AIR FILTER
4. OIL DIPSTICK
5. OIL FILTER
6. REV. SENSOR
7. OIL PRESSURE SENSOR
8. OIL PRESSURE ADJUSTING VALVE
9. SEAWATER PUMP
10. FRESH WATER TEMPERATURE SENSOR
11. THERMOSTAT

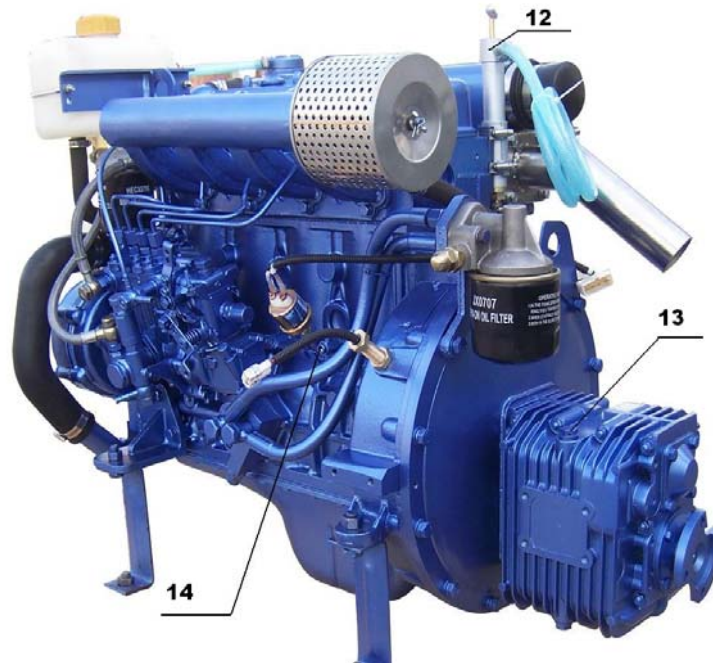

- 12. SUMP PUMP
- 13. DIPSTICK (AS FOR GEAR BOX)
- 14. FRESH WATER COCK

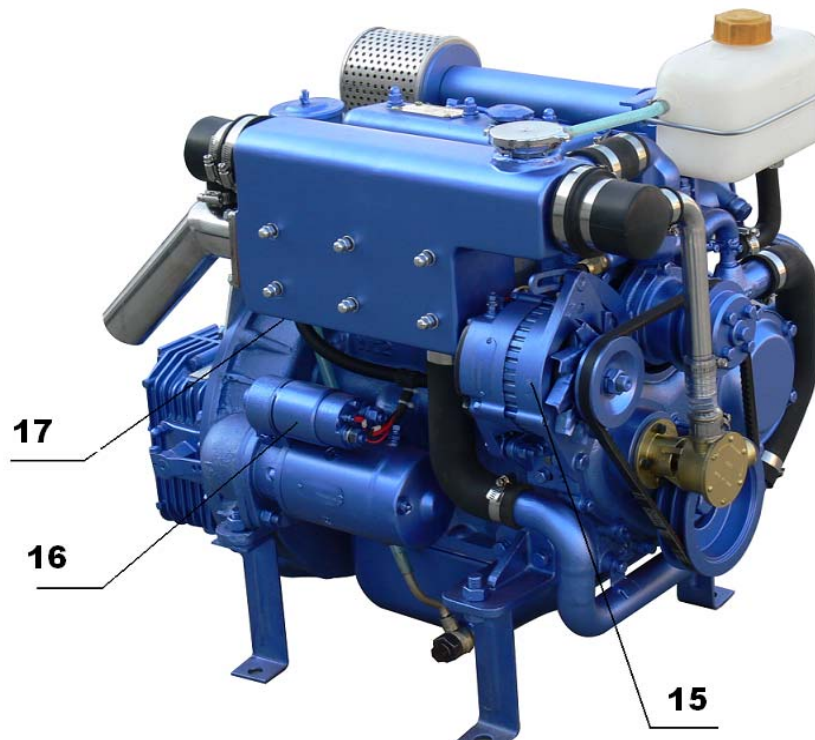

- 15. Alternator
- 16. Start motor
- 17. Zinc anode

4. Running Instructions

4.1 Starting the engine

4.1.1 Switch on the main switch, Start the engine room fan (if fitted) and allow it to run for several minutes before starting the engine.

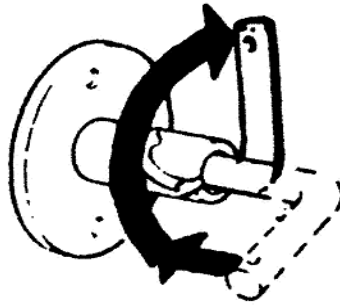

4.1.2 Check the fuel cock and bottom sea water cock are in open position. Pump out any water in the boat with the bilge pump.

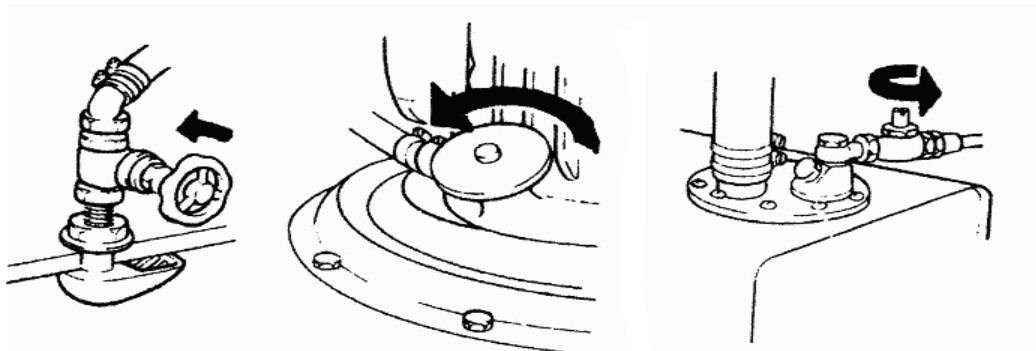

4.1.3 Release the throttle control from the gear shift control as follows: press the release button (1) in when the lever is in the neutral position, and then move the lever slightly forwards. Release the button. The control lever will now operate the engine speed only.

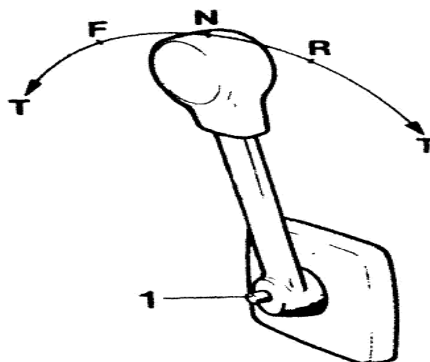

4.1.4 Turn the starter key to position 1, the electric system are power in, all meters light up.

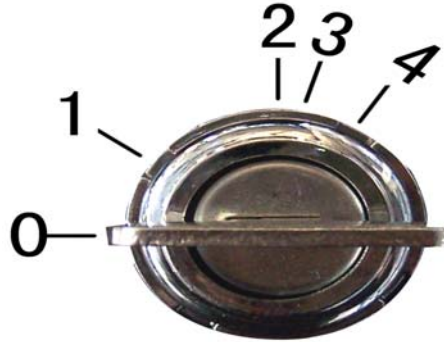

4.1.5 Press the alarm button to make sure that the alarm is working.

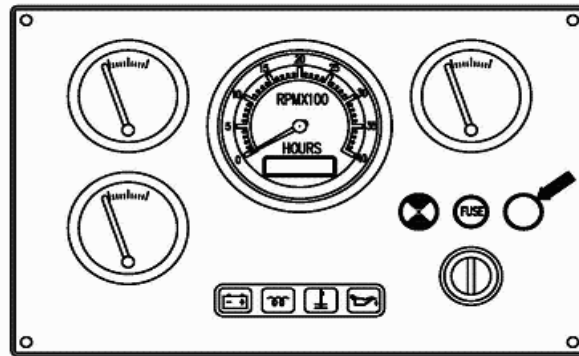

4.1.6 turn the starter key to position 2, the solenoid will be working, turn the key between 3 and 4, the pre-heater will working, turn the key to position 4, engine will be started, release the key when the engine has started. When the engine is running, the key should be in position 3. **Before restarting the engine, return the key to position 0.**

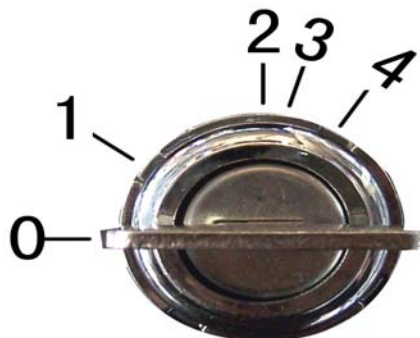

4.1.7 Immediately after starting the engine, check that the oil pressure gauge and the voltmeter show normal readings and that alarm is not sounding, if the readings are abnormal and the alarm is sounding, stop the engine immediately and investigate the case.

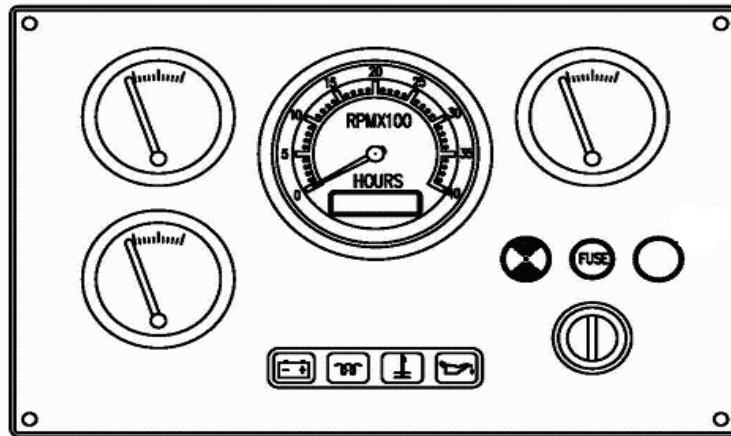

4.1.8 If the engine temperature and battery charging lamp lights up, but the alarm does not sound, there is a charging fault.

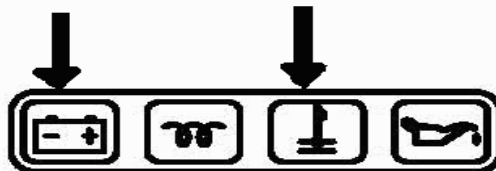

4.1.9 If the engine temperature or oil pressure lamps light up and alarm sounds, either the engine temperature is too high or the oil pressure is too low, and you should stop the engine and investigate the case.

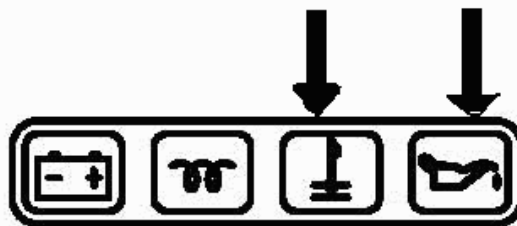

4.1. 10 The single control lever combines the throttle and gear shift functions.

F= Forward

R= Reverse

N= Neutral

T= Throttle

WARNING! Never change travel direction before the engine has returned to idling speed.

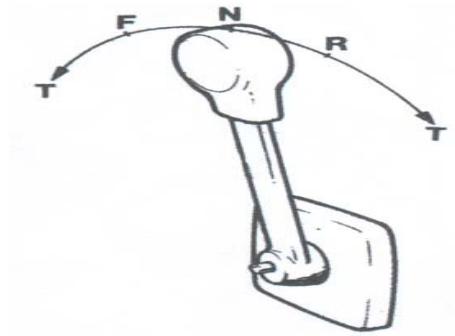

4.1.11 For best results, do not run the engine at maximum revolutions for long periods.

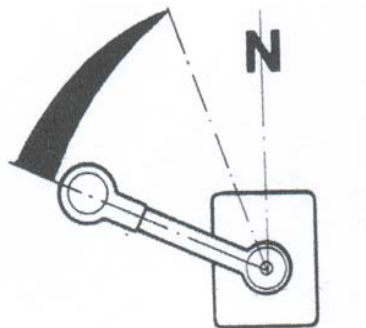

4.1. 12 Stop the engine at once if the alarm sounds and the signal lamps light up, turn the key back to position 1, engine will be shut off.

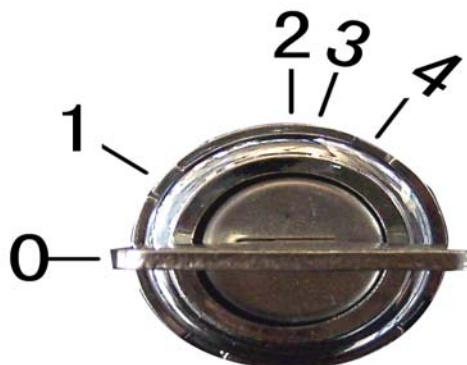

4.1. 13 When under sail, the control lever should be in the neutral position if the propeller is a fixed propeller. If the propeller is a folding propeller, the control lever should be in the reverse position. Start the engine and run it for 5 minutes every ten hours when on long-distance cruises.

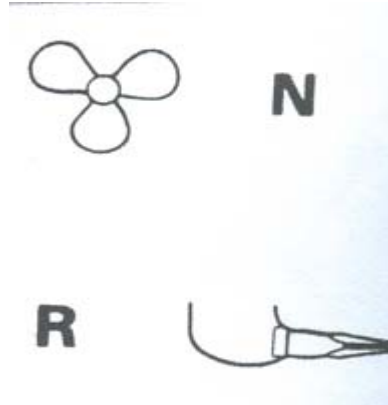

4.1.14 Note: Do not switch off the main switch before the engine has stopped.

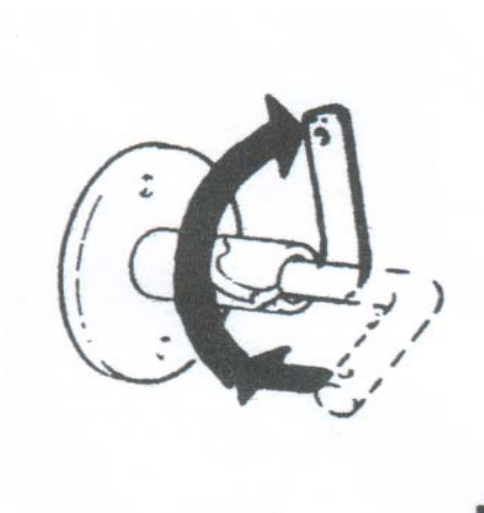

4.2 Shutdown Procedure

4.2.1 Before shutting down the engine, it should be allowed to idle for a few minutes, with the control lever in the neutral position.

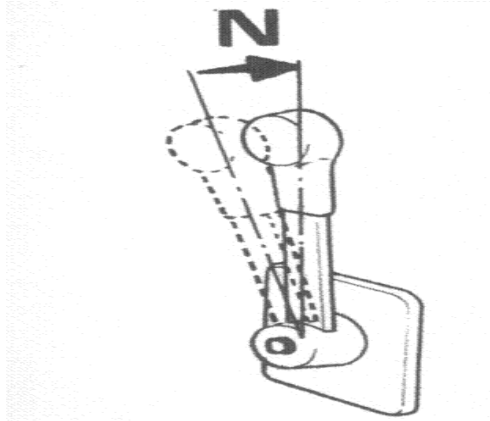

4.2.2 Stop the engine by key when the engine is idling.

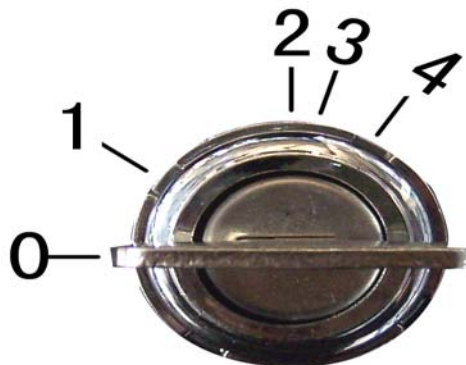

4.2.3 Switch off the main switch. **IMPORTANT!** The main switch must never be switched off until the engine has stopped. Close the fuel and cooling water cock during long intervals between using. Before leaving the boat, check that no leakages have occurred.

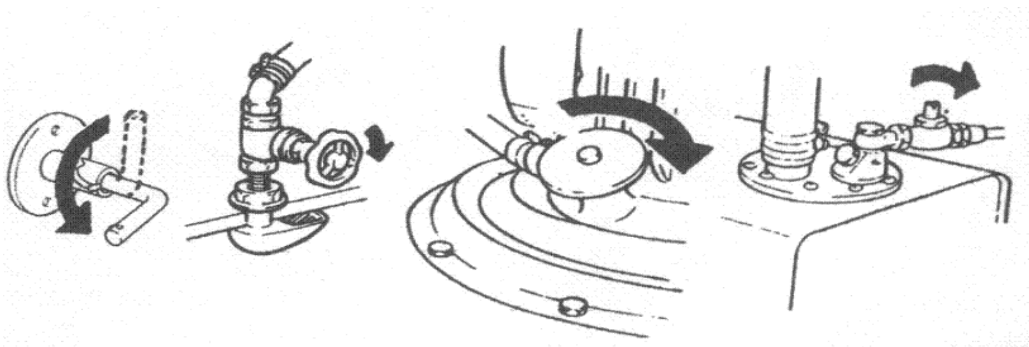

4.2 Frost Risk

If the engine is fitted with a fresh water cooling system, it should be filled with a 50:50 mixture of anti-freeze and water, or alternatively drained off.

4.3 Draining off fresh water systems

To drain off the fresh water cooling system, open the cock on the side of the engine block.

4.4 Draining off sea water systems

Unfasten the cover on the sea water pump.

Unfasten the hose on the reverse gear.

Remove the pipe.

Close the cocks and refasten the cover on the sea water pump before leaving the boat.

5. Checks and Service

5.1 Check daily before starting

5.1.1 Check oil level

Check the oil level every day before starting the engine, to make sure that it's within the dipstick marking for maximum and minimum levels, and that you have enough oil for the journey you are planning.

Fill up with oil when necessary. See "Technical Data" for type of oil to be used.



5.1.2 Check water cooling level (Fresh water systems)

Check every day before starting the engine that the water level in the expansion tank is within the marking for maximum and minimum levels.

When necessary, fill up with fresh water or corrosion inhibitive anti freeze mixture. When there is a danger of frost it is important to ensure that the fresh water system is filled with anti freeze. Alternatively, the system can be drained. For draining the sea water system see under “Shut down Procedure”.

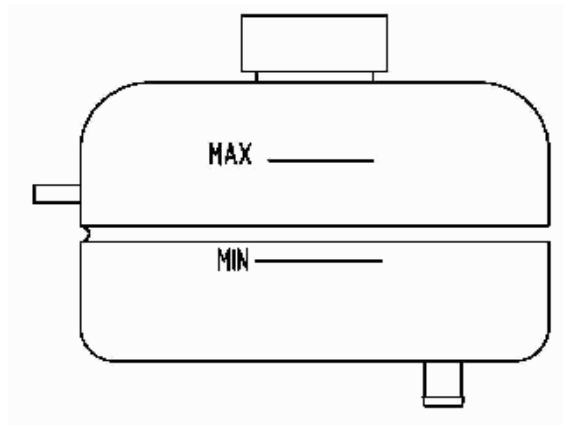

5.2 Check every 14 days

5.2.1 Check oil level in gearbox

Check the oil level is within the dipstick marking for maximum and minimum levels, Fill up with oil when necessary, but do not exceed the maximum level. See “Technical Data” for type of oil to be used.

5.2.2 Check the belt tension

The V-belt must be correctly tensioned in order to obtain full alternator output. When it is properly tensioned, it should be possible to push the belt down about 5 mm midway between the pulleys within your thumb.

To tension the belt, first loosen the mounting nut for the alternator. Worn or cracked belts should be replaced.

5.2.3 Check electrolyte level in battery

The electrolyte level in the battery should be 5-10mm above the cell plates. Fill up with distilled water when necessary.

Warning: Exercise great care when filling as the gas formed in the battery is explosive and the acid caustic.

5.3 Service first 20 hours of operation

5.3.1 Change oil filter

Run the engine until it is warm. Pump up the oil through the hole for the dipstick, and then refill with oil to the correct level. See: "Technical Data" for type of oil to be used. Note: The oil filter should be changed at the same time as every second change of engine oil.

5.4 Service every 100 hours of operation

5.4.1 Change oil filter

The oil filter should be changed after the first 20 hours of running, and thereafter at every second of engine oil.

Screw off the filter and throw it away.

Coat the rubber seal of the new filter with oil.

Check the contact surface on the engine, and then screw the filter on by hand until it is just touching the contact surface. Tighten the filter another half turn. Do not tighten it any further.

Start the engine, let it idle and check that the oil pressure lamp goes out. Check the oil level, and that there are no leakage around the filter.

5.4.2 Clean intake silencer

The intake silencer should be cleaned each season. Loosen the intake silencer, wash in diesel oil and rinse thoroughly, Re-fit the intake silencer.

5.4.3 Change oil in gearbox

The oil in the gearbox should be cleaned after 200 hours or at least once a season. Remove the plug under the gearbox and allow the oil to run out, Then reinsert the plug and fill up with oil. Make sure that the oil level is between the maximum and minimum levels indicated on the dipstick.

Note: Do not exceed the maximum level. See "technical Data" for type and volume of oil to be used.

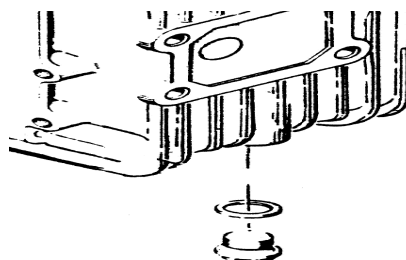

5.4.4 Check/change the impeller

The impeller may become damaged, for example through lack of water in the pump due to blocked intake. Close the bottom cock. Then remove the pump cover and inspect the impeller. If it has been damaged it should be replaced. Remove the impeller with a pair of adjustable pliers, and fit a new. Then refit the pump cover with a new seal. Open the bottom cock again.

Warning: Watch out for water leakage.

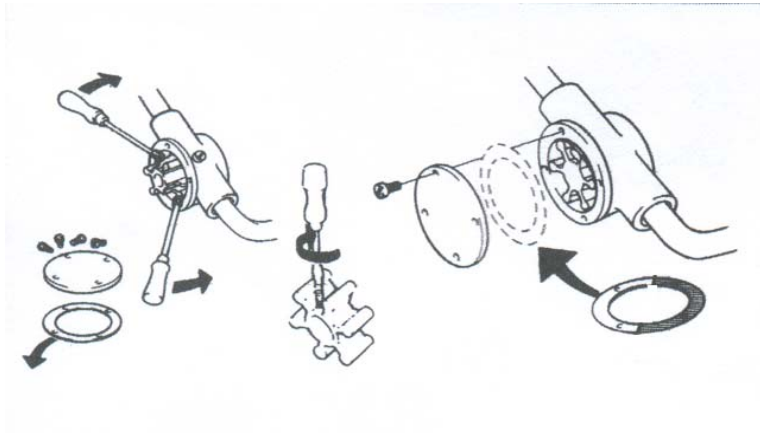

5.4.5 Check the valve clearance

Checking and adjusting the valve clearance should only be done by professional. See "Valve" under "Technical Data".

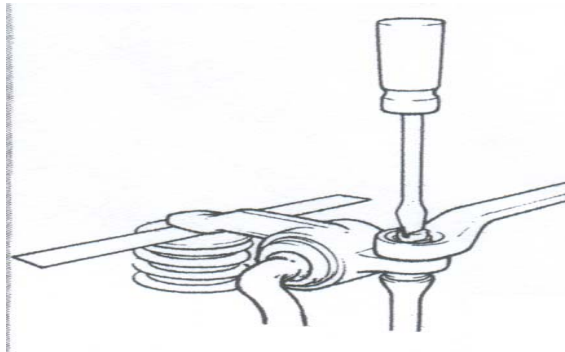

5.4.6 Check starter and alternator

Checking and maintenance work on the starter and alternator should only be done by professional.

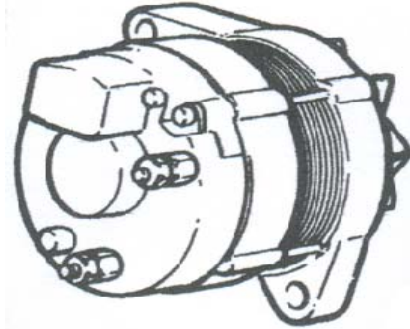

5.4.7 Check cooling system

If the cooling system is functioning normally, the “TEMP” lamp will not be lit up. If the temperature is too high and the lamp lights up, the cause maybe one of the following:

Blocked water intake

Defective impeller in sea water pump

Defective thermostat or temperature gauge

Warning: Watch out for water leakage whenever you are working on the cooling system

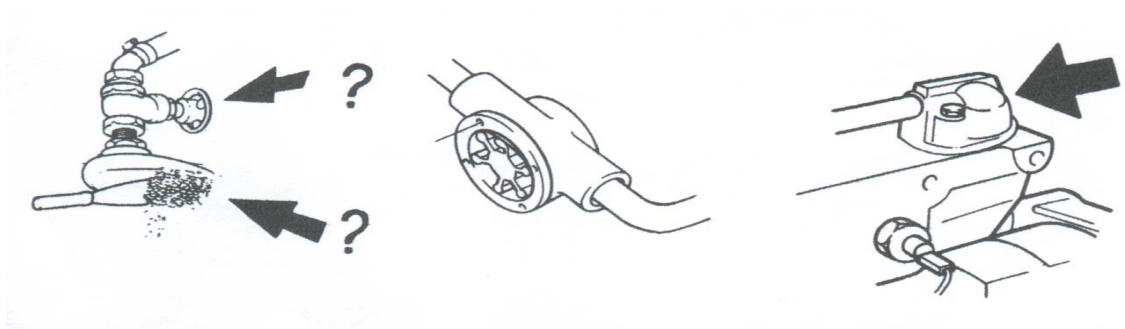

5.4.8 Changing the fuse

The fuse box included in the electrical system is mounted on the electrical unit. The fuse will disconnect the electricity supply if it is overloaded. You can reconnect the circuit by wiring up to the next terminal.

6. Laying up and launching

6.1 Inhibiting

While the boat is in the water but not in use, the engine should be run warm at least once every 14 days. If the boat is not to be used for over a month at a time, long-term inhibiting should be carried out.

6.2 Long-term inhibiting

You should have the engine and its accessories checked by professional before carrying out long-term inhibiting, and see that any necessary repairs are carried out at this point.

6.3 Inhibiting schedule (with boat in water)

6.3.1 Allow the engine to idle at high revolutions for a few minutes.

Then stop it.

6.3.2 Pump all oil out of the engine using the oil pump and drain off the oil out of the gearbox.

6.3.3 Change the oil filter. Fill the engine and gearbox to the correct level.

The engine is then ready to run on this oil next season.

When inhibiting for longer periods than normal laying-up for the winter, special preservative oil should be used, and the oil filter should not be changed until the boat is launched again.

6.3.4 Change the fuel filter

6.3.5 Clean the filter screen and vent the fuel system

6.3.6 Loosen the venting screw on the fuel filter about 4 turns. Watch out for fuel splashing.

6.3.7 Pump up the fuel using the hand primer until the fuel is flowing out free of air bubbles. Tighten the venting screw again.

The fuel injection pump is vented automatically when the engine is started.

6.4 Inhibiting schedule (with boat on land)

6.4.1 Fresh water cooled engine

If the fresh water system has already been filled with ethylene glycol or similar corrosion inhibitive fluid, check the anti-freeze. If the system has been filled and then filled with a 50/50 mixture of water and ethylene glycol.

6.4.3 Sea water system

Prepare a 50/50 mixture of fresh water and anti-freeze glycol or similar corrosion inhibitive fluid, and insert the hose in it. Arrange for the collection of the fluid when it has run through the engine before you start. Then start the engine and let it idle until all the mixture has been used up.

Note: The pump must not be allowed to run dry.

6.5 Launch the boat

6.5.1 If the propeller shaft is fitted with a rubber stuffing box, press in grease before launching.

6.5.2 The stuffing box should be vented after launching.

Warning: The rubber stuffing box must be replaced after 500 hours or 5 years.

7. Tracking faults

7.1 Engine doesn't start

If the start motor does not turn over, check whether the battery is flat. Use a hydrometer to measure the specific gravity of the electrolyte. Check that the cables for the battery and starter motor are properly connected. If the battery is sufficiently charged and you hear a clicking noise from the starter solenoid when the starter key is turned, the start motor itself maybe defective. If you cannot hear this clicking noise then there maybe a defect in the solenoid, the key switch or the wiring for them.

7.2 Engine does not start, or stalls

If the start motor does turn over, but the engine either will not start, or keeps stalling, check that you have fuel in the fuel tank and that the fuel cock is open. If the engine is fitted with an extra fuel filter, there should be fuel visible in the glass or metal optic. Check that fuel is reaching the injectors by unscrewing the pressure pipe on the injector, and then turn the engine over using the starter motor. If no fuel appears it may mean that the filter is blocked, the fuel pump is defective, or that there is air in the system. Change all the filters and vent the system. If not fuel appears after this, either the feed pump or the injector pump maybe defective.

If fuel does come out of pressure pipe when you carryout this test, it may mean that one of the injectors is defective. Change the injectors and try to start the engine again. If the engine still will not start the fault is probably in the injector pump. You should take it to a professional. Check the position of the stop cable.

7.3 Uneven running or excessive vibration

Most interferences in engine running are caused by defects in the fuel supply system, which in turn are often the result of water, air or impurities getting into the fuel. You should therefore change all the filters and vent the system, and perhaps change the injectors. Check that all fuel pipes are properly connected.

Rather more infrequently, it may be that the trouble is caused by loss of compression in one or more of the cylinders. Compression should be checked by professional.

7.4 Engine over heats

If the engine is overheating, check to see if:

The thermostat is faulty

The impeller is defective

The cooling water intake or jackets are blocked. (if yes, dismantle and clear them)

7.5 Engine does not attain full revolutions

If the engine starts properly and runs smoothly, but does not reach the same revolutions as previously, this does not necessarily indicate a defect in the engine, but may mean that there is fouling on the bottom of the boat, or that it is over loaded. It is also possible that the propeller maybe defective. If all these causes can be eliminated, there may have been a loss of compression in one or more of the cylinders. Compression losing should be checked by professional.

7.6 Aligning engine and gearbox

Once a season or after launching, the alignment of the engine with the propeller shaft should be checked and if necessary adjusted. To do this:

Unfasten the screw union for the propeller shaft flange. Using a 0.10mm thickness gauge, check that there is not enough room to insert it between the reverse gear and propeller shaft flange any point when the propeller shaft is pushed forwards. Turn the shaft through 90, 180 and 270 when carrying out this test. If the gap is more than 0.10 mm the alignment should be adjusted. If a non-adjustable rubber suspension is fitted, the thickness of the padding should be adjusted.

Main technical specifications

Model	TDME-380	TDME-385	TDME-480	TDME-485	TDME-490	TDME-4102	TDME-4105
Type	Vertrical, water-cooling, 4-stroke, direct-injection combustion chamber						
No. of cylinders	3			4			
Bore (mm)	80	85	80	85	90	102	105
Stroke (mm)	90	90	90	95	105	118	118
Total displacement (L)	1.357	1.532	1.809	2.156	2.67	3.857	4.087
Rated power (HP)	27	32	37	46	58	70	80
Rated speed(r/min)	3000	3000	3000	3000	3000	2500	2500
Exhaust system	Water cooling						
Lubrication method	Pressure and splash						
Fuel	Diesel						
Net weight(kg)	250	260	290	300	360	560	600

9. Electric Wiring Diagrams

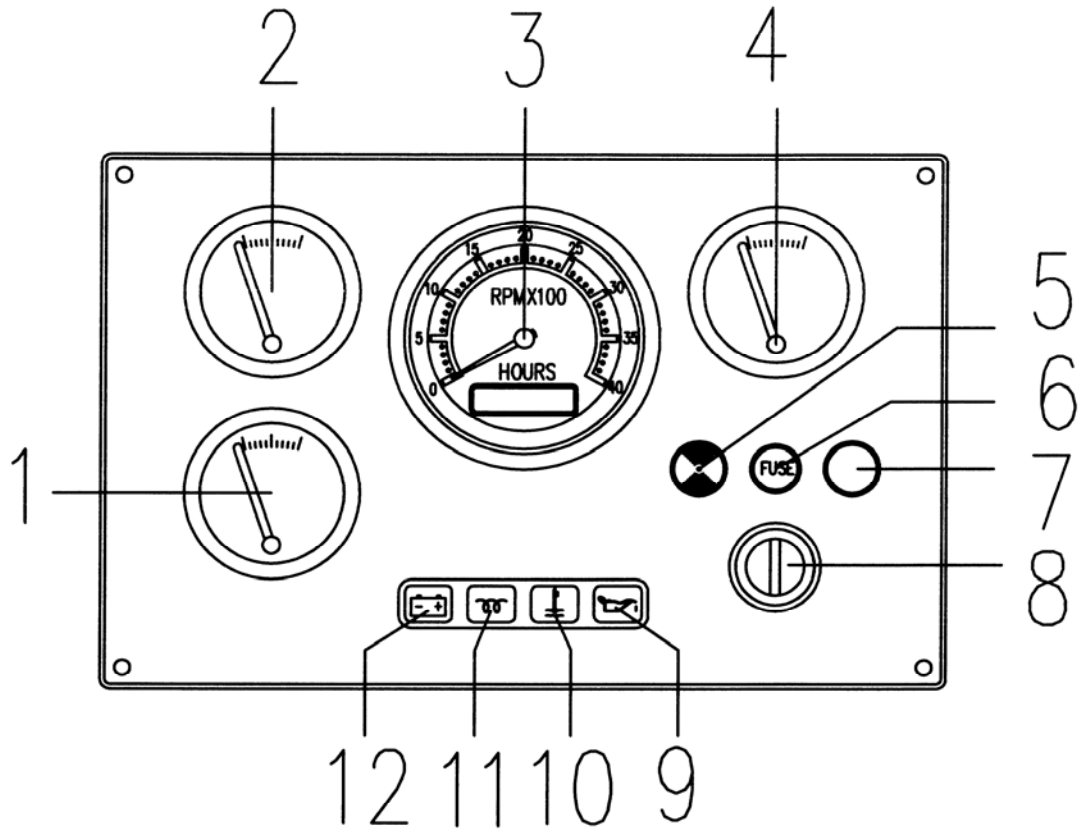

1. Oil pressure gauge
2. Temperature gauge for cooling water (Fresh water), normal cooling water temperature 75-90°C
3. Rev counter with operating hour meter
4. Volt meter
5. Alarm (buzzer), "Low oil pressure", "Temperature too high"
6. Fuse
7. Alarm check
8. Key switch
9. Warning lamp, low oil pressure
10. Warning lamp, high water temperature
11. Preheater
12. Warning lamp, no charging

