

Rotek AS440 compatible VOLTAGE REGULATOR (AVR)

SPECIFICATION INSTALLATION AND ADJUSTMENTS

General description

AS440 is a half wave phase controlled thyristor type AVR and forms part of the excitation system for a brushless generator. The design employs Surface Mount Technology (SMT) for high integration of features in a small footprint AVR.

Positive voltage build up from residual levels is ensured by the use of efficient semiconductors in the power circuitry of the AVR. The power and voltage sensing circuits have separate terminals, allowing the excitation power to be derived directly from the stator winding for basic applications or from an auxiliary winding if sustained short circuit performance is required.

The AVR is linked with the main stator windings and the exciter field windings to provide closed loop control of the output voltage with load regulation of +/- 1.0%.

The AVR voltage sensing terminals continuously sample the output windings for voltage control purposes. In response to this sample voltage, the AVR controls the power fed to the exciter field, and hence the main field, to maintain the machine output voltage within the specified limits, compensating for load, speed, temperature and power factor, of the generator.

A frequency measuring circuit continually monitors the generator output and provides under-speed protection of the excitation system, by reducing the output voltage proportionally with speed below a pre-settable threshold. A manual adjustment is provided for factory setting of the under frequency roll off point, (UFRO). This can easily be changed to 50 or 60 Hz in the field by push-on link selection.

Over excitation conditions are limited to a safe period by a protection circuit within the AVR.

Provision is made for the connection of a remote voltage trimmer, allowing the user fine control of the generator's output.

An analogue input is provided allowing connection to the Power Factor controller or other external devices with compatible output.

The AVR has the facility for droop CT connection, to allow parallel running with other similarly equipped generators.

Technical specification

SENSING INPUT

Voltage	Jumper selectable 100-130 Vac 1 phase or 190-264 Vac 1 phase
Frequency	50-60 Hz nominal

POWER INPUT

Voltage	100-264 V ac 1 phase
Frequency	50-60 Hz nominal

OUTPUT

Voltage	82 V d.c. @ 200 V a.c.
Current	continuous 4A (see note 1). transient 7.5A for 10 secs.
Resistance	15 ohms min (10 ohms min when input volts is less than 175 ac)

REGULATION

+/- 1.0% (see note 2)

THERMAL DRIFT

0.03% per deg. C change in AVR ambient (see note 3)

TYPICAL SYSTEM RESPONSE

AVR response	20 ms
Field current to 90%	80 ms
Machine Volts to 97%	300 ms

EXTERNAL VOLTAGE ADJUSTMENT

+/-10% with 1 k ohm 1 watt trimmer (see note 4)
Increasing resistance lowers voltage.

UNDER FREQUENCY PROTECTION

Set point 94 -98% Hz (see note 5)

UNIT POWER DISSIPATION

12 watts maximum

BUILD UP VOLTAGE

4 Volts @ AVR terminals

ANALOGUE INPUT

Maximum input +/- 5 Vdc (see note 6)
Sensitivity 1V for 5% Generator Volts (adjustable)
Input resistance 1k ohm

QUADRATURE DROOP INPUT

10 ohms burden
Max. sensitivity: 0.07 A for 5% droop 0PF
Max. input: 0.33 A

OVER EXCITATION PROTECTION

Set point 65 V dc
Time delay 10-15 seconds (fixed)

ENVIRONMENTAL

Vibration	20-100 Hz 100Hz – 2kHz	50mm/sec 3.3g
Operating temperature		-40 to +70C (note 7)
Relative Humidity	0-70C	95% (note 8)
Storage temperature		-55 to +80C

NOTES

1. De-rate by 12% if mounted in 'portrait' orientation.
2. With 4% engine governing.
3. After 2 minutes.
4. Generator de-rate may apply. Check with factory.
5. Factory set, semi-sealed, jumper selectable.
6. Any device connected to the analogue input must be fully floating (galvanically isolated from ground), with an insulation strength of 500V ac.
7. De-rate output current by 5% per degree C above 60C.
8. Non condensing.

DESIGN DETAIL

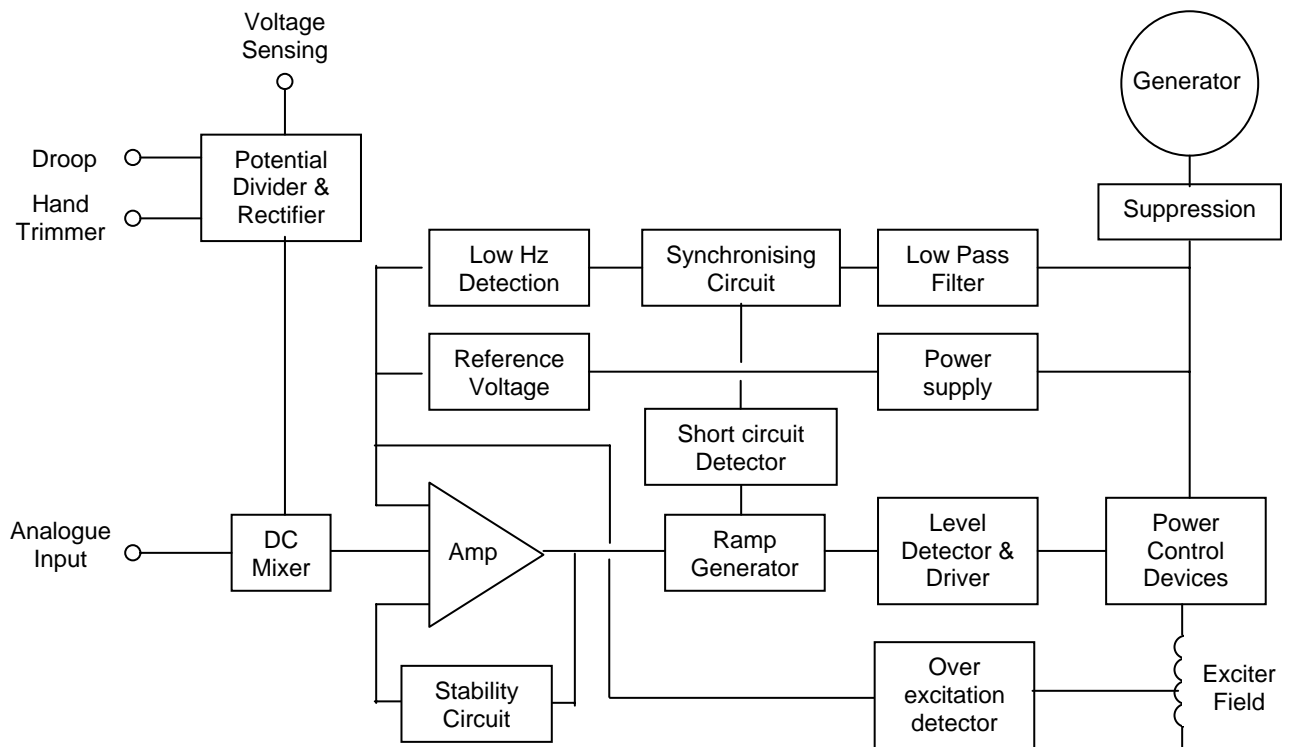

The main functions of the AVR are:

The Potential Divider and Rectifier takes a proportion of the generator output voltage and attenuates it. The potential divider is adjustable by the AVR Volts potentiometer and external hand trimmer (when fitted). The output from the droop CT is also added to this signal. A rectifier converts the a.c. input signal into d.c. for further processing.

The DC Mixer adds the Analogue input signal the Sensing signal.

The Amplifier (Amp) compares the sensing voltage to the Reference Voltage and amplifies the difference (error) to provide a controlling signal for the power devices. The Ramp Generator and Level Detector and Driver infinitely control the conduction period of the Power Control Devices and hence provides the excitation system with the required power to maintain the generator voltage within specified limits.

The Stability Circuit provides adjustable negative ac feedback to ensure good steady state and transient performance of the control system.

The Low Hz Detector measures the period of each electrical cycle and causes the reference voltage to be reduced approximately linearly with speed below a presettable threshold. A Light Emitting Diode gives indication of underspeed running.

The Synchronising circuit is used to keep the Ramp Generator and Low Hz Detector locked to the generator waveform period.

The Low Pass Filter prevents distorted waveforms affecting the operation of the AVR control circuit.

The Short Circuit Detector senses the presence of a short circuit on the generator output and forces the Power Control Devices into full conduction. This only occurs when the AVR is powered from an auxiliary winding.

Power Control Devices vary the amount of exciter field current in response to the error signal produced by the Amplifier.

Suppression components are included to prevent sub cycle voltage spikes damaging the AVR components and also to reduce the amount of conducted noise on the generator terminals.

The Over Excitation Detector continuously monitors the exciter field voltage and provides signals, to collapse the output voltage if an over excitation condition persists for the specified time period.

The Power Supply provides the required voltages for the AVR circuitry.

FITTING AND OPERATING

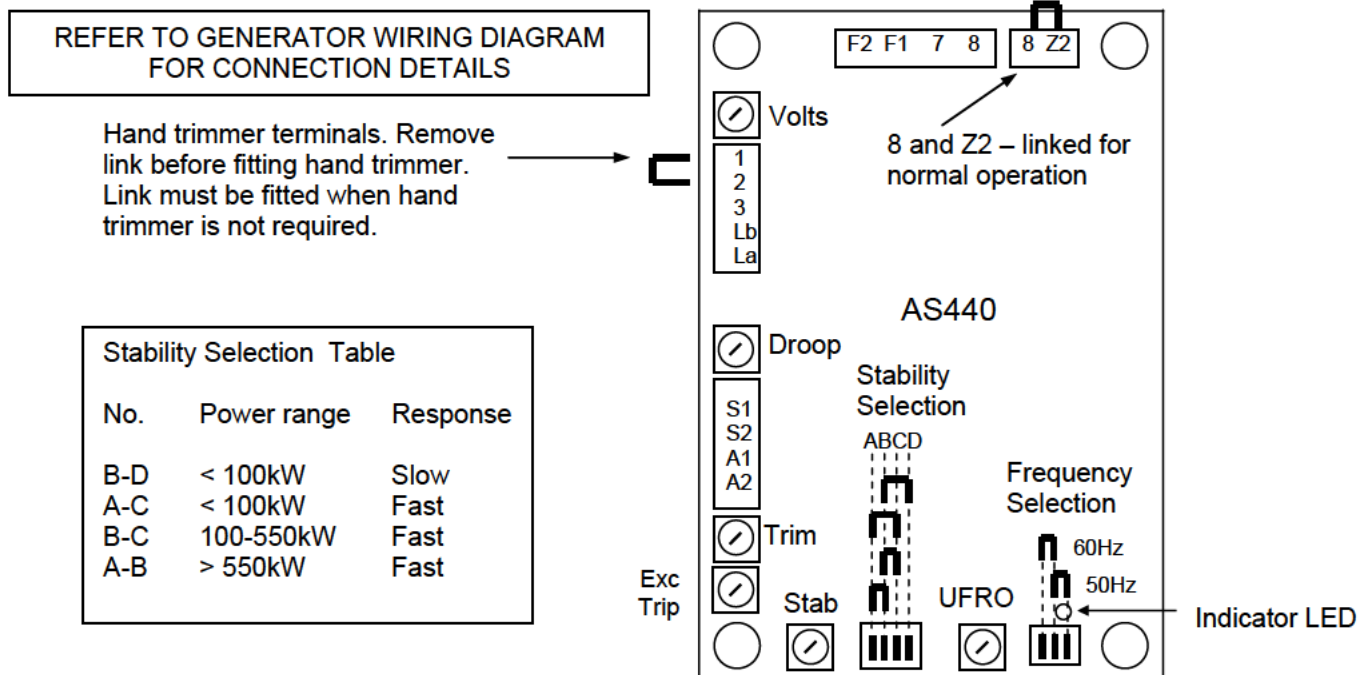

SUMMARY OF AVR CONTROLS		
CONTROL	FUNCTION	DIRECTION
VOLTS	TO ADJUST GENERATOR OUTPUT VOLTAGE	CLOCKWISE INCREASES OUTPUT VOLTAGE
STABILITY	TO PREVENT VOLTAGE HUNTING	CLOCKWISE INCREASE THE DAMPING EFFECT
STAB SWITCH	TO OPTIMISE TRANSIENT PERFORMANCE	SEE TABLE ABOVE
UFRO	TO SET THE UFRO KNEE POINT	CLOCKWISE REDUCES THE KNEE POINT FREQUENCY
DROOP	TO SET THE GENERATOR DROOP TO 5% AT 0PF	CLOCKWISE INCREASES THE DROOP
VTRIM	TO OPTIMISE ANALOGUE INPUT SENSITIVITY	CLOCKWISE INCREASES THE GAIN OR SENSITIVITY
EXC TRIP	TO SET OVER EXCITATION TRIP CUT OFF LEVEL	CLOCKWISE INCREASES THE CUT OFF LEVEL

ADJUSTMENT OF AVR CONTROLS

VOLTAGE ADJUSTMENT

The generator output voltage is set at the factory, but can be altered by careful adjustment of the VOLTS control on the AVR board, or by the external hand trimmer if fitted. If major adjustment is necessary or you lose stability, follow the 'VOLTAGE SETUP PROCEDURE'.

Terminals 1 and 2 on the AVR will be fitted with a shorting link if no hand trimmer is required. Terminals La and Lb are linked only for special low voltage applications.

WARNING! Do not increase the voltage above the rated generator voltage. If in doubt, refer to the rating plate mounted on the generator case.

WARNING! Do not ground any of the hand trimmer terminals as these could be above earth potential. Failure to observe this could cause equipment damage.

WARNING!

If a replacement AVR has been fitted or re-setting of the VOLTS adjustment is required, turn the VOLTS control fully anti-clockwise before running generator.

VOLTAGE SETUP PROCEDURE

For major adjustments and replacing the AVR. **Read and understand this procedure before attempting to follow it.**

1. Before running generator, turn the VOLTS control fully anti-clockwise.
2. Turn remote volts trimmer (if fitted) to midway position.
3. Turn STABILITY control to midway position.
4. Connect a suitable voltmeter (0-300V ac) across line to neutral of the generator.
5. Start generator set, and run on no load at nominal frequency e.g. 50-53Hz or 60-63Hz.
6. If the red Light Emitting Diode (LED) is illuminated, refer to the Under Frequency Roll Off (UFRO) adjustment.
7. Carefully turn VOLTS control clockwise until rated voltage is reached.
8. If instability is present at rated voltage, refer to stability adjustment, then re-adjust voltage if necessary.
9. Voltage adjustment is now completed.

FITTING AND OPERATING

STABILITY ADJUSTMENT

The AVR includes a stability or damping circuit to provide good steady state and transient performance of the generator.

A switch is provided to change the response of the stability circuit to suit different frame size generators and applications. The table shows the options available.

The slow response settings may prove helpful in reducing lamp flicker.

The correct setting of the Stability adjustment can be found by running the generator at no load and slowly turning the stability control anti-clockwise until the generator voltage starts to become unstable.

The optimum or critically damped position is slightly clockwise from this point (i.e. where the machine volts are stable but close to the unstable region).

UNDER FREQUENCY ROLL OFF (UFRO) ADJUSTMENT

The AVR incorporates an underspeed protection circuit which gives a volts/Hz characteristic when the generator speed falls below a presettable threshold known as the "knee" point.

The red Light Emitting Diode (LED) gives indication that the UFRO circuit is operating.

The UFRO adjustment is preset and sealed and only requires the selection of 50/60Hz using the jumper link.

For optimum setting, the LED should illuminate as the frequency falls just below nominal, i.e. 47Hz on a 50Hz system or 57Hz on a 60Hz system.

DROOP ADJUSTMENT

Generators intended for parallel operation are fitted with a quadrature droop C.T. which provides a power factor dependent signal for the AVR. The C.T. is connected to S1, S2 on the AVR.

The DROOP adjustment is normally preset in the works to give 5% voltage droop at full load zero power factor.

Clockwise increases the amount of C.T. signal injected into the AVR and increases the droop with lagging power factor ($\cos \phi$). With the control fully anti-clockwise there is no droop.

TRIM ADJUSTMENT

An analogue input (A1 A2) is provided to connect to a Power Factor Controller or other devices. It is designed to accept dc signals up to +/- 5 volts.

WARNING! Any devices connected to this input must be fully floating and galvanically isolated from ground, with an insulation capability of 500 Vac. Failure to observe this could result in equipment damage.

The dc signal applied to this input adds to the AVR sensing circuit. A1 is connected to the AVR 0 volts. Positive on A2 increases excitation. Negative on A2 decreases excitation.

The TRIM control allows the user to adjust the sensitivity of the input. With TRIM fully anti-clockwise the externally applied signal has no effect. Clockwise it has maximum effect.

Normal setting is fully clockwise when used with a Power Factor Controller.

OVER EXCITATION (EXC TRIP) ADJUSTMENT

The adjustment is set and sealed in the works and should not be altered.

An over excitation condition is indicated on the common LED which also indicates under speed running.

The generator must be stopped to reset an over excitation condition.

ISOLATING THE EXCITATION CIRCUIT

In some applications it is desirable to isolate the excitation circuit. There are two different ways of doing this depending on the AVR connection to the generator stator.

The modifications mentioned below must be done with the generator at rest.

If the AVR is fitted with a link across the 2 way terminal block Z2 & 8, then the AVR power circuit is connected to the main stator winding. In this case a switch with a Nominal rating of 240vac 10 Amps can be connected across the AVR terminals Z2 & 8 after removing the link.

When the switch is open, the excitation circuit is isolated. The link should be kept for future use if required.

If the AVR has a wire connected to terminal Z2 (wire labeled Z2), then the AVR power circuit is connected to an auxiliary winding. In this case a switch with a nominal rating of 240vac 10 Amps can be connected in series with the wire Z2.

When the switch is open, the excitation circuit is isolated

WIRING AND DIAGRAM

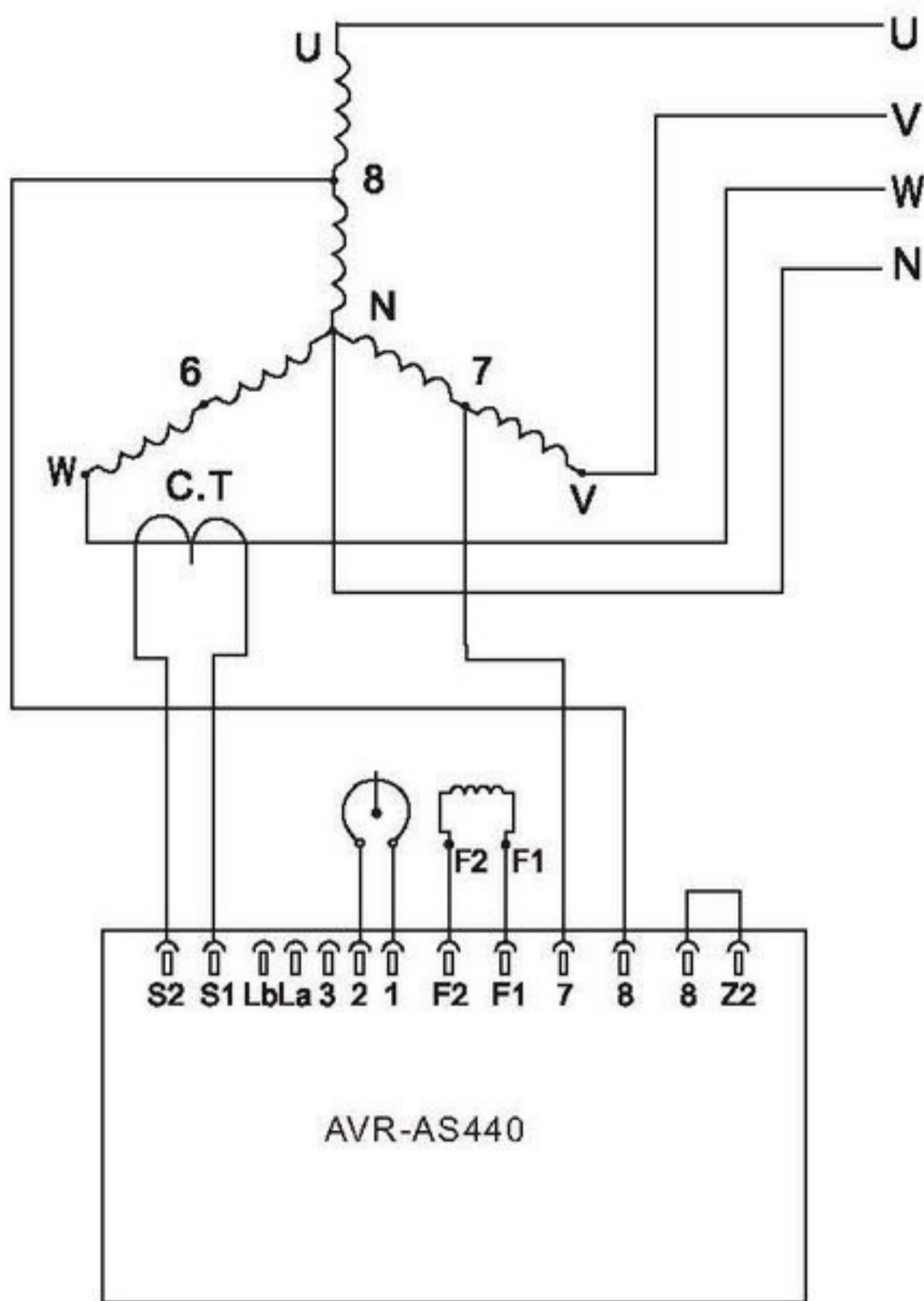

Wiring of generator with 12-line terminals, 240/415V or 277/480V, 3 phases 4 wires

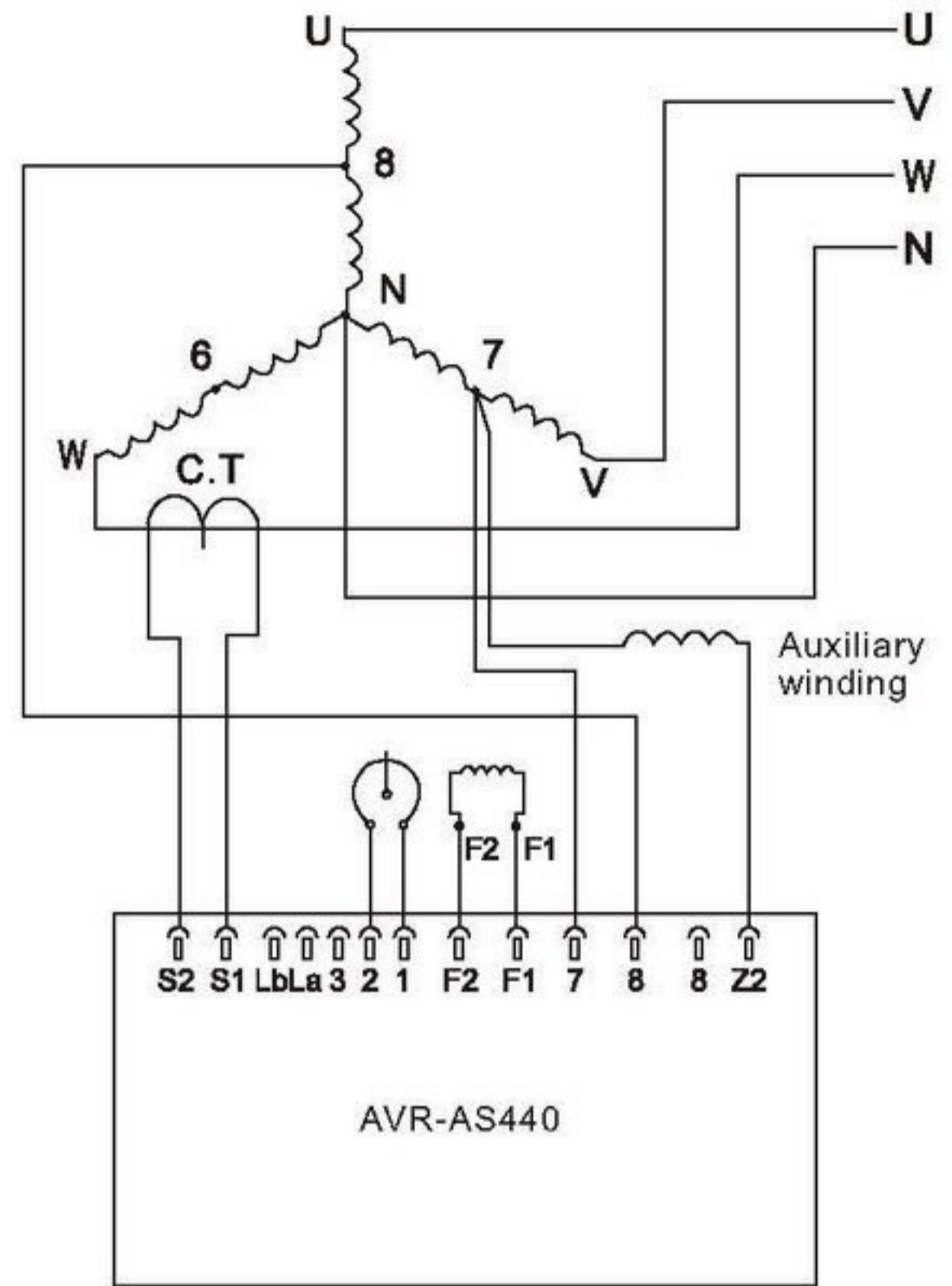

(Fundamental wave auxiliary winding)
Wiring of generator with 12-line terminals, 240/415V or 277/480V, 3 phases 4 wires

