

Metal Oxide Varistors

Varistor>32D201~162K Series



Applications

- Transistor, diode, IC, thyristor or triac semiconductor protection.
- Surge protection in consumer electronics.
- Surge protection in industrial electronics.
- Surge protection in electronic home appliances, gas and petroleum appliances.
- Relay and electromagnetic valve surge absorption.

Features

- Wide operating voltage (V1mA) range from 8V to 1800V.
- Fast responding to transient over-voltage.
- Large absorbing transient energy capability.
- Low clamping ratio and no following-on current.

General Information

The MOV-32DxxxK Series of 32mm radial leaded varistor devices protects against overvoltage transients such as lightning, power contact and power induction. The metal oxide varistors offer a choice of varistor voltages from 200 V to 1600 V and Vrms voltages from 130 V to 1000 V.

The devices have a high current handling, high energy absorption capability and fast response times to protect against transient faults up to rated limits.

General Characteristics

No Radioactive Material

Storage Temperature: -55°C to +125°C

Operating Temperature: -55°C to +85°C

Body: Nickel Plated

Leads: Surface-mount, Axial Devices: Tin Plated

Devices with No Leads: Nickel Plated

Packaging Information

Part Number	Component package	Quantity	Packaging Option	Packaging Specification
32D	32.0	100	BOX	200PCS

Product Name

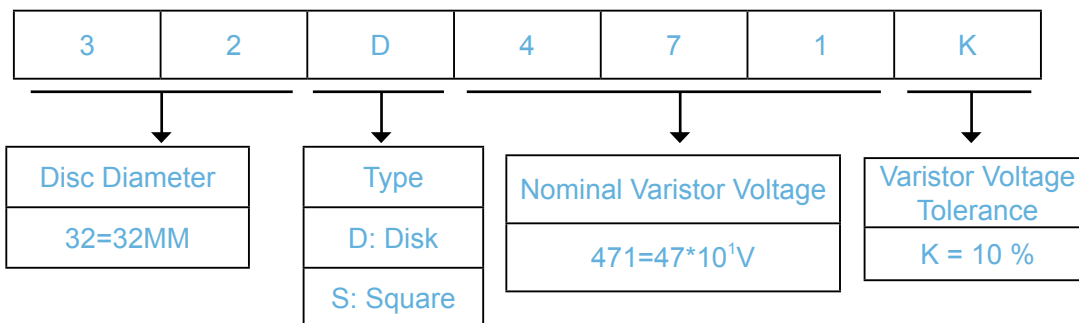

Electrical Characteristics (@ TA = 25 °C Unless Otherwise Noted)

Type Number	Maximum Allowable Voltage		Varistor Voltage $V_{1mA}(V)$	Maximum Clamping Voltage		Withstanding Surge Current $I(A)$	Maximum Energy (10/1000 μ s) (J)	Typical Capacitance (Reference) @1KHz(pf)
	$V_{AC}(V)$	$V_{DC}(V)$		$I_P(A)$	$V_C(V)$			
32D201K	130	170	200(180~220)	200	340	20000	250	5200
32D221K	140	180	220(198~242)	200	360	20000	270	5150
32D241K	150	200	240(216~264)	200	395	20000	290	5100
32D271K	175	225	270(243~297)	200	455	20000	300	4800
32D301K	190	250	300(270~330)	200	500	20000	330	4550
32D331K	210	275	330(297~363)	200	550	20000	360	4300
32D361K	230	300	360(324~396)	200	595	20000	380	3900
32D391K	250	320	390(351~429)	200	650	20000	400	3200
32D431K	275	350	430(387~473)	200	710	20000	430	3100
32D471K	300	385	470(423~517)	200	775	20000	460	2800
32D511K	320	415	510(459~561)	200	845	20000	510	2700
32D561K	350	460	560(504~616)	200	925	20000	540	2550
32D621K	385	505	620(558~682)	200	1025	20000	570	2400
32D681K	420	560	680(612~748)	200	1120	20000	600	2200
32D751K	460	615	750(675~825)	200	1240	20000	620	2000
32D781K	485	640	780(702~858)	200	1290	20000	660	1900
32D821K	510	670	820(738~902)	200	1355	20000	700	1800
32D911K	550	745	910(819~1001)	200	1500	20000	750	1300
32D951K	575	765	950(855~1045)	200	1570	20000	780	1200
32D102K	625	825	1000(900~1100)	200	1650	20000	810	1100
32D112K	680	895	1100(990~1210)	200	1815	20000	910	1000
32D122K	750	990	1200(1080~1320)	200	1980	20000	960	920
32D142K	880	1140	1400(1260~1540)	200	2310	20000	1020	800
32D162K	1000	1280	1600(1440~1760)	200	2640	20000	1080	700

Current Energy and Power Dissipation Ratings

Should transients occur in rapid succession, the average power dissipation is the energy (watt-seconds) per pulse times the number of pulses per second. The power so developed must be within the specifications shown on the Device Ratings and Specifications Table for the specific

device. The operating values of a MOV need to be derated at high temperatures as shown above. Because varistors only dissipate a relatively small amount of average power they are not suitable for repetitive applications that involve substantial amounts of average power dissipation.

Figure 1A - Power Derating for Epoxy Coated

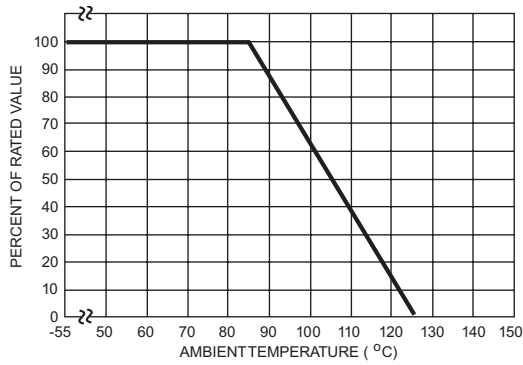
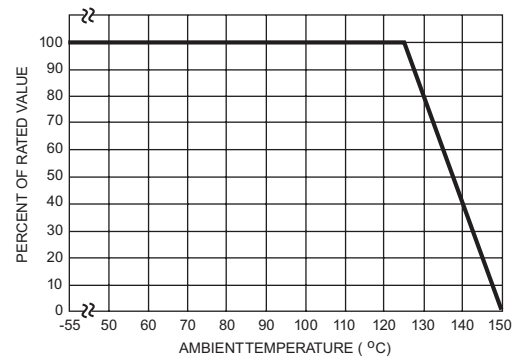

Figure 1B - Power Derating for Pholenic Coated



Peak Pulse Current Test Waveform

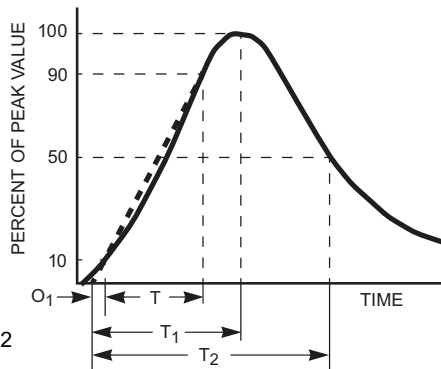

Figure 2

- O_1 = Virtual Origin of Wave
- T = Time from 10% to 90% of Peak
- T_1 = Rise Time = $1.25 \times T$
- T_2 = Decay Time

Example - For an 8/20 μ s Current Waveform:

- $8\mu\text{s} = T_1 = \text{Rise Time}$
- $20\mu\text{s} = T_2 = \text{Decay Time}$

Package Dimensions

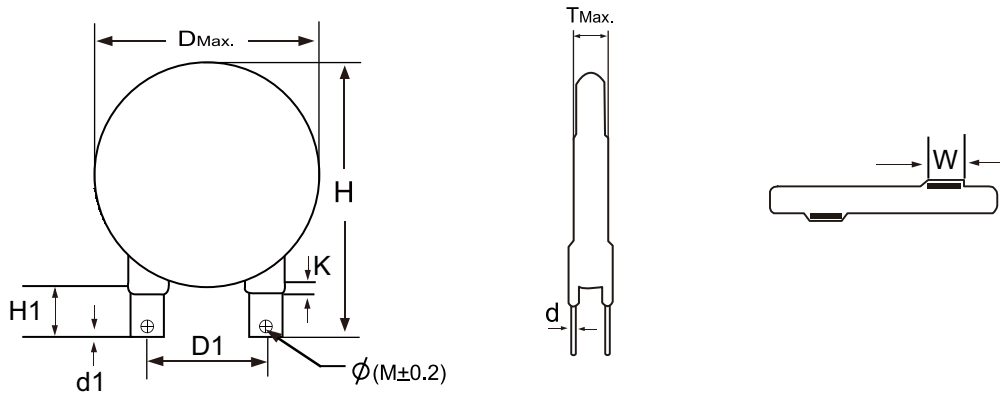

Unit:mm

TABLE 1

Symbol	Dimensions
H(max.)	60.2
H1(max.)	16.5
D(max.)	45
D1(+1.0)	25.4
T(max.)	TABLE 2
d(+0.1)	0.5
d1(+0.3)	3.4
K(max.)	3.18
W(+0.5)	7.0
$\phi(M \pm 0.2)$	3.8

TABLE 2

Model	T(max.)	Model	T(max.)
201K	6.2	621K	8.7
221K	6.3	681K	9.0
241K	6.4	751K	9.4
271K	6.6	781K	9.6
301K	6.8	821K	9.8
331K	6.9	911K	10.4
361K	7.1	951K	10.6
391K	7.3	102K	11.2
431K	7.5	112K	11.8
471K	7.8	122K	12.3
511K	8.0	142K	13.3
561K	8.3	162K	14.3