

Metal Oxide Varistors

Varistor>34S201~162K Series



Applications

- Transistor, diode, IC, thyristor or triac semiconductor protection.
- Surge protection in consumer electronics.
- Surge protection in industrial electronics.
- Surge protection in electronic home appliances, gas and petroleum appliances.
- Relay and electromagnetic valve surge absorption.

Features

- Wide operating voltage (V1mA) range from 8V to 1800V.
- Fast responding to transient over-voltage.
- Large absorbing transient energy capability.
- Low clamping ratio and no following-on current.

General Information

The MOV-34SxxxK Series of 34 mm radial leaded varistor devices protects against overvoltage transients such as lightning, power contact and power induction. The metal oxide varistors offer a choice of varistor voltages from 200 V to 1600 V and Vrms voltages from 130 V to 1000 V.

The devices have a high current handling, high energy absorption capability and fast response times to protect against transient faults up to rated limits.

General Characteristics

No Radioactive Material

Storage Temperature: -55°C to +125°C

Operating Temperature: -55°C to +85°C

Body: Nickel Plated

Leads: Surface-mount, Axial Devices: Tin Plated

Devices with No Leads: Nickel Plated

Packaging Information

Part Number	Component package	Quantity	Packaging Option	Packaging Specification
34S	34.0	100	BOX	200PCS

Product Name

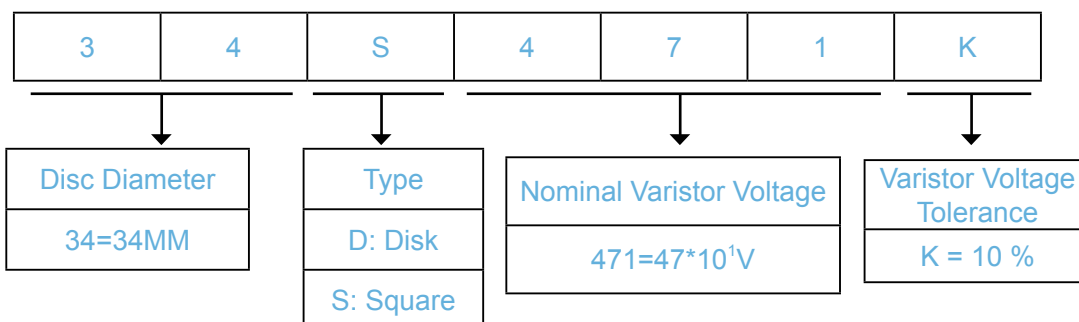

Electrical Characteristics (@ TA = 25 °C Unless Otherwise Noted)

Type Number	Maximum Allowable Voltage		Varistor Voltage	Maximum Clamping Voltage		Withstanding Surge Current	Maximum Energy (10/1000µs)	Typical Capacitance (Reference)
	V _{AC} (V)	V _{DC} (V)		V _{1mA} (V)	I _P (A)			
34S201K	130	170	200(180~220)	300	340	40000	330	8000
34S221K	140	180	220(198~242)	300	360	40000	360	7800
34S241K	150	200	240(216~264)	300	395	40000	390	7600
34S271K	175	225	270(243~297)	300	455	40000	420	7200
34S301K	190	250	300(270~330)	300	500	40000	460	7000
34S331K	210	275	330(297~363)	300	550	40000	500	6400
34S361K	230	300	360(324~396)	300	595	40000	510	6000
34S391K	250	320	390(351~429)	300	650	40000	530	4800
34S431K	275	350	430(387~473)	300	710	40000	600	4600
34S471K	300	385	470(423~517)	300	775	40000	650	4100
34S511K	320	415	510(459~561)	300	845	40000	700	4000
34S561K	350	460	560(504~616)	300	925	40000	730	3800
34S621K	385	505	620(558~682)	300	1025	40000	780	3600
34S681K	420	560	680(612~748)	300	1120	40000	810	3300
34S751K	460	615	750(675~825)	300	1240	40000	850	3000
34S781K	485	640	780(702~858)	300	1290	40000	930	2850
34S821K	510	670	820(738~902)	300	1355	40000	970	2700
34S911K	550	745	910(819~1001)	300	1500	40000	1050	2100
34S951K	575	765	950(855~1045)	300	1570	40000	1080	1900
34S102K	625	825	1000(900~1100)	300	1650	40000	1120	1700
34S112K	680	895	1100(990~1210)	300	1815	40000	1250	1520
34S122K	750	990	1200(1350~1650)	300	1980	40000	1250	1400
34S142K	880	1140	1400(1260~1540)	300	2310	40000	1400	1200
34S162K	1000	1280	1600(1440~1760)	300	2640	40000	1500	1100

Current Energy and Power Dissipation Ratings

Should transients occur in rapid succession, the average power dissipation is the energy (watt-seconds) per pulse times the number of pulses per second. The power so developed must be within the specifications shown on the Device Ratings and Specifications Table for the specific

device. The operating values of a MOV need to be derated at high temperatures as shown above. Because varistors only dissipate a relatively small amount of average power they are not suitable for repetitive applications that involve substantial amounts of average power dissipation.

Figure 1A - Power Derating for Epoxy Coated

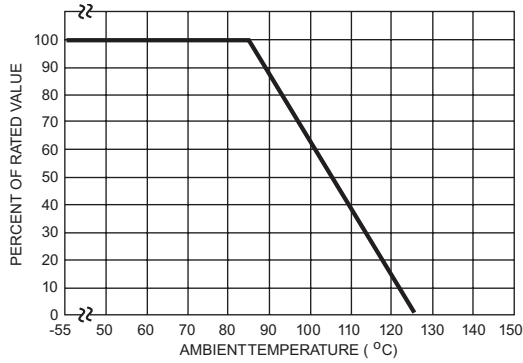
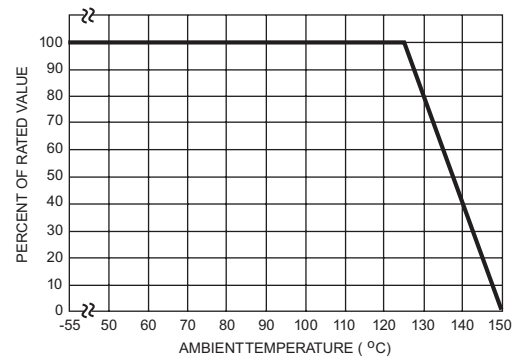

Figure 1B - Power Derating for Pholenic Coated



Peak Pulse Current Test Waveform

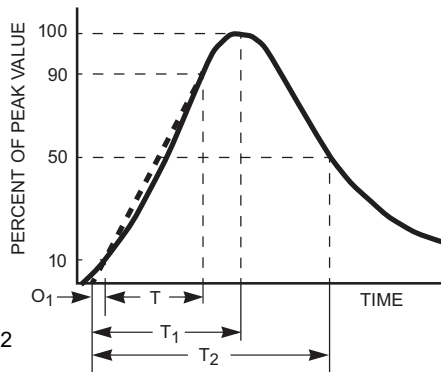

Figure 2

- O_1 = Virtual Origin of Wave
- T = Time from 10% to 90% of Peak
- T_1 = Rise Time = $1.25 \times T$
- T_2 = Decay Time

Example - For an 8/20 μ s Current Waveform:

- $8\mu\text{s} = T_1$ = Rise Time
- $20\mu\text{s} = T_2$ = Decay Time

Package Dimensions

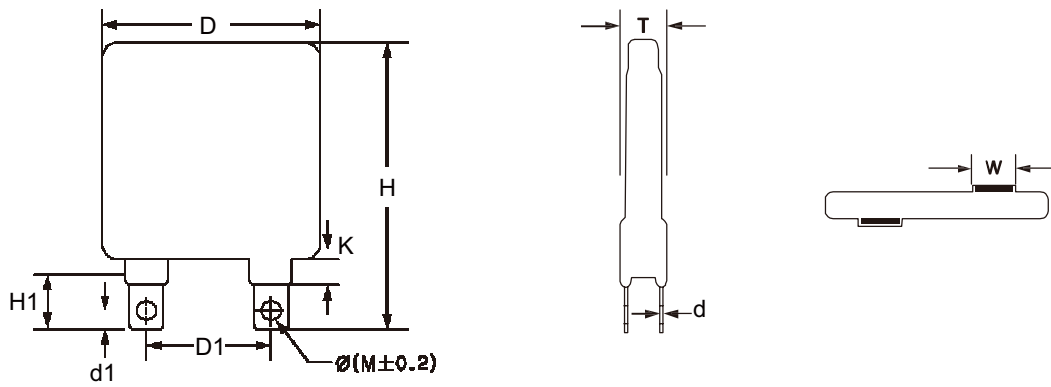

Unit:mm

TABLE 1

Symbol	Dimensions
H(max.)	56.3
H1(max.)	16.5
D(max.)	40.0
D1(+1.0)	25.4
T(max.)	TABLE 2
d(+0.1)	0.5
d1(+0.3)	3.4
K(max.)	3.18
W(+0.5)	7.0
(M+0.2)	3.8

TABLE 2

Model	T(max.)	Model	T(max.)
201K	6.2	621K	8.7
221K	6.3	681K	9.0
241K	6.4	751K	9.4
271K	6.6	781K	9.6
301K	6.8	821K	9.8
331K	6.9	911K	10.4
361K	7.1	951K	10.6
391K	7.3	102K	11.2
431K	7.5	112K	11.8
471K	7.8	122K	12.3
511K	8.9	142K	13.3
561K	8.3	162K	14.3